

Hpe[®] mini

**Hardware prototyping and
evaluation board**

Altera Cyclone™ II EP2C35 based

Hpe[®] mini

Hpe is the abbreviation of "Hardware prototyping and evaluation". For this purpose, usually expensive hardware is necessary. A financial effort, that many companies cannot afford.

We are proud to present a cheap alternative to access this market: The Hpe_mini is a low cost version of the Hpe_compact board, which is being used successfully by the industry. Since it comprehends the basic Hpe_compact functions, it is easy to upgrade later on.

The block diagram stated below is an example for a *1 clock/machine-cycle 8051*, which runs up to 30 MHz. We can deliver this CPU with different applications, for example as a WEB server.

The Hpe_mini is mainly used for

- SOC development of 8 - 32 bit systems
- Special solutions for controller and interfaces
- Development of complex design

Many universities and training centres world-wide use this board for teaching and research. In order to get the most out of a course, every attendee should be equipped with an own board. Our low-cost development platform is ideally suited for that.

In addition you can use a 32 bit LEON3 CPU, an ARM bus compatible SPARC8 CPU, the complete system with Ethernet, UART's, Interrupt Controller and Debug Support Unit needs less than 50% of the available logic elements. LINUX is available. Please ask us for details.

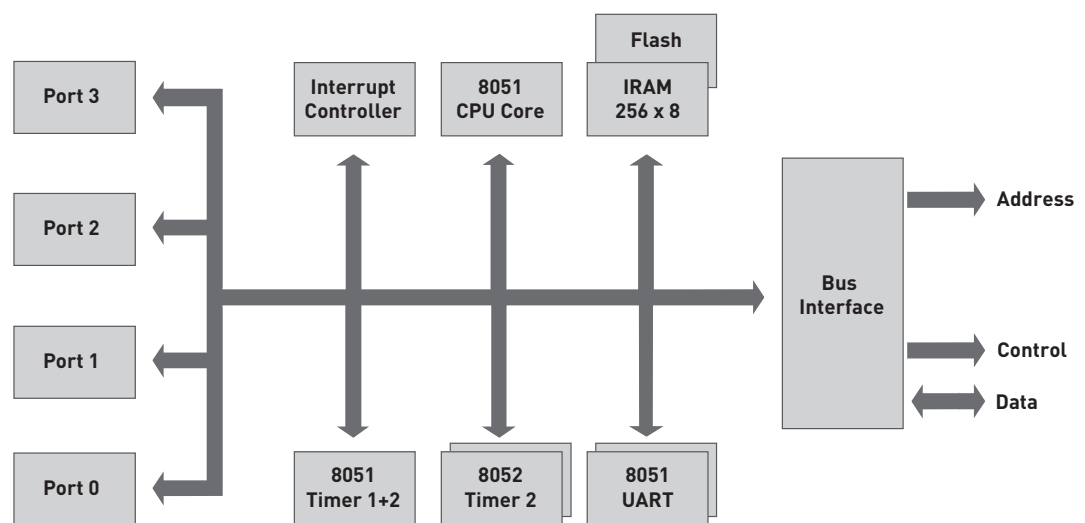

Power Management



Application example (developed with ge-research library)

Functionality and interfaces

- Altera Cyclone™ II FPGA
- Reprogrammable Flash Memory for configuration of the FPGA and as external non-volatile memory for processor program
- Parallel connector (LPT, 25-pin) for programming the FPGA/Configuration Flash via JTAG interface
- Serial connector (RS232, 9-pin)
- VGA connector (15-pin)
- Ethernet 10/100M, full/half duplex
- USB (3 host, 1 target)
- "Santa Cruz" connector with 40 useable I/Os
- Audio interface (lineIN and lineOUT) with CODEC
- Ext. components for 6-10 bit D/A
- Prototyping area for individual assembly/wiring
- SDRAM connector (SODIMM144)
- Power supply connector for 5V
- Oscillator (25 MHz)
- Human interface – consists of:
 - 8 x LEDs
 - Dual digit seven segment display
 - LCD connector (16-pin)
 - 3 x 4 key matrix
 - 4 x DIP switches
 - Debounced button e.g. for single step
 - Status LEDs (Power Good, Configuration Done)

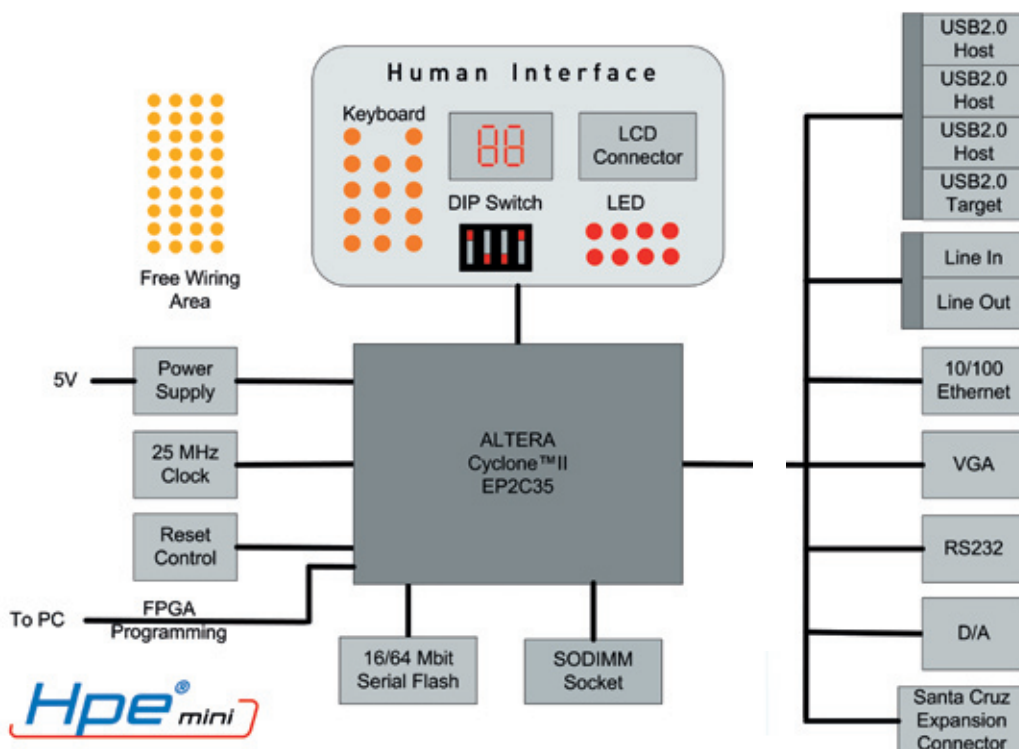

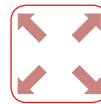

Included in delivery:

- Hpe_mini gold or silver
- Power supply
- Programming cable
- GER board support package (applications, all data sheets and manuals as pdf files)

Silver Edition	Gold Edition
EP2C35-C8 (~330 MHz)	EP2C35-C6 (~390 MHz)
EP2CS16 16 Mbit Flash	EP2CS64 64 Mbit Flash

The Hpe_mini comes with a board support package. This software includes all functions to develop the design for the FPGA.

Altera Quartus II Web Edition

- Graphical design entry using the SOPC Builder
- Integrated VHDL and Verilog HDL synthesis
- Placement, routing and verification
- NIOS II™ ready

Gleichmann Electronics Research free IPs

- UART, I2C, CAN 2.0b, USB, Ethernet, LCD controller, ...
- 8052 VHDL code
Keil monitor on demand
Complete webserver application available
- LEON3 (32-bit, IEEE-1754 SPARC V8) VHDL code, complete development environment and LINUX
- Several test programs in VHDL source code

Additionally available:



SDR SODIMM module
256MB



LCD Truly 2*20
char. with cable

Detailed information on this product as well as all pricing information is available under www.ger-fae.com.

GE Research

Phone: +43 7236 3343 499
Mail: sales@ger-fae.com
www.ger-fae.com

